

VC MIPI Camera Module Hardware Operating Manual

Hardware specifications of VC MIPI Camera Modules

Revision: 1.3

Date: 2021-02-03

Contact: support@vision-comp.com

Copyright: 1996-2021 Vision Components GmbH Ettlingen, Germany

Author: VC Support, <mailto:support@vision-comp.com>

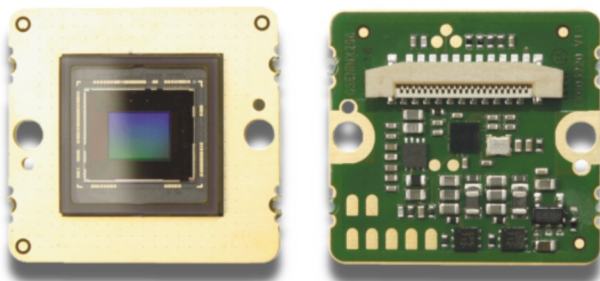

Foreword and Disclaimer

This documentation has been prepared with most possible care. However Vision Components GmbH does not take any liability for possible errors. In the interest of progress, Vision Components GmbH reserves the right to perform technical changes without further notice.

Please notify support@vision-components.com if you become aware of any errors in this manual or if a certain topic requires more detailed documentation.

This manual is intended for information of Vision Component's customers only. Any publication of this document or parts thereof requires written permission by Vision Components GmbH.

Image symbols used in this document

Symbol	Meaning
	The Light bulb highlights hints and ideas that may be helpful for a development.
	This warning sign alerts of possible pitfalls to avoid. Please pay careful attention to sections marked with this sign.
	This is a sign for an example.

Trademarks

Linux, Debian, the Tux logo, Vivado, Xilinx and Zynq, ARM, Cortex, Windows XP, Total Commander, Tera Term, Motorola, HALCON, Vision Components are registered Trademarks. All trademarks are the property of their respective owners.

Nvidia, Jetson, Asus, Raspberry Pi and Raspbian are also registered Trademarks.

ESD sensitivity

Warning



The components are very sensitive to electrostatic discharge (ESD)! Please take all the precautions necessary to avoid ESD!

ESD



The electronic components and circuits are sensitive to ElectroStatic Discharge (ESD). When handling any circuit board assemblies, it is necessary that ESD safety precautions be observed.

ESD safe best practices include, but are not limited to:

- Leaving circuit boards in their antistatic packaging until they are ready to be installed.
- Using a grounded wrist strap when handling circuit boards.
- Working on a grounded ESD table mat.
- Only handling circuit boards in ESD safe areas, which may include ESD floor and table mats, wrist strap stations and ESD safe lab coats.
- Avoiding handling circuit boards in carpeted areas.
- Try to handle the board by the edges, avoiding contact with components.

This note is not an exhaustive information about the protection against electrostatic discharge (ESD).

Table of Contents

- 1 General Information**
 - 1.1 Hardware Compatibility
 - 1.2 Technical Specification
 - 1.3 Electrical and Mechanical Prerequisites
 - 1.4 Pin Cable Connector for Vision Components MIPI CSI camera modules
 - 1.4.1 Flexible Printed Circuit (FPC) Cable
 - 1.5 MIPI Sensor Module Circuit
 - 1.6 Trigger Timing
- 2 Ordering Information**
 - 2.1 MIPI camera module order numbers
 - 2.2 Order numbers of MIPI camera module Accessories
- 3 Appendix A: Dimensions MIPI camera module**
 - 3.1 VC MIPI IMX296 (same board dimensions for OV9281, OV7251, IMX297, IMX290, IMX327, IMX412, IMX415)
 - 3.2 VC MIPI IMX183 (same board dimensions for IMX252, IMX250, IMX392)
 - 3.3 VC MIPI IMX226 (same board dimensions for IMX273)

1 General Information

1.1 Hardware Compatibility

MIPI-Modules can be connected to a number of different computer boards like the

- Raspberry Pi 3, 3B, 3B+, 4B (with a 22-to-15 FPC cable)
- Raspberry Compute Module - CMIO Rev. 3.0 (with a 22pin FPC cable)
- Asus Tinker board (with a 22-to-15 FPC cable)
- 96boards computer boards (with 22pin FPC cable and the VC MIPI 96 Adapter Board, EK003348)
- Nvidia Jetson TX2 development board (with 15pin FPC cable and Auvideo J20 adapter board)
- Nvidia Jetson Nano development board (directly with 15pin FPC cable)
- Nvidia Jetson Xavier NX development board (directly with 15pin FPC cable)
- Nvidia Jetson AGX Xavier development board (with 15pin FPC cable and Auvideo J20 adapter board)
- Trenez Electronic ZynqBerry TE0726 SoC module (directly with 15pin FPC cable)
- Toradex Verdin iMX8M Mini

Note



VC performs compatibility tests for a number of boards on a regular basis and publishes the results. However, no guarantee for the sensor hardware compatibility for any third party board can be given.

1.2 Technical Specification

Please note that the achievable frame and data transmission rates depend on the number of lanes and/or the capabilities of the receiving endpoint. The fps shown at the table are the maximum possible values for the MIPI modules.

Technical Data: VC MIPI IMX296/VC MIPI IMX296 C, VC MIPI IMX297, VC MIPI OV9281

Component / Feature	Module Name VC MIPI IMX296/VC MIPI IMX296 C	Module Name VC MIPI IMX297	Module Name VC MIPI OV9281
CMOS Sensor	1/2.9" Sony IMX296, Mono/color, 1.56 Mpixel	1/2.9" Sony IMX297, Mono, 0.39 Mpixel	1/4" Omnivision OV9281, Monochrome, 1.02 Mpixel
Active pixels	1440(H) x 1080(V)	720(H) x 540(V)	1280(H) x 800(V)
Pixel size	3.45(H) x 3.45(V) μm	6.90(H) x 6.90(V) μm	3(H) x 3(V) μm
Active sensor size	4.968(H) x 3.726(V) mm	4.968(H) x 3.726(V) mm	3.840(H) x 2.400(V) mm
Shutter type	Global shutter	Global shutter	Global shutter
ADC Resolution	10 Bit	10 Bit	8 bit / 10 bit
CSI-2 output	1 lane / RAW 10	1 lane / RAW 10	2 lane / RAW 8 or RAW 10
CSI-2 maximum speed	1.2 Gbps/lane max.	1.2 Gbps/lane max.	800 Mbps/lane max.
CSI-2 default speed	1.2 Gbps/lane	1.2 Gbps/lane	800 Mbps/lane
Max fps (full resolution)	60.3 fps	120 fps	120 fps / 60 fps externally triggered
Output modes	streaming mode, fast trigger mode	streaming mode, fast trigger mode	streaming mode, trigger mode
Shutter resolution	in streaming mode: 1 horizontal unit, in fast trigger mode: 18.5nsec	in streaming mode: 1 horizontal unit, in fast trigger mode: 18.5nsec	in streaming mode: 1 horizontal unit, in trigger mode: 1 horizontal unit
Gain	0–24dB analog gain + 0–24dB digital gain	0–24dB analog gain + 0–24dB digital gain	analog and digital gain
S/N ratio	n/a	n/a	38dB
dynamic range	n/a	n/a	68dB
HDR	No	No	No
CRA	1.8 degrees	1.8 degrees	9 degrees
ROI / cropping support	Yes, but no speed increase	Yes, but no speed increase	Yes, but no speed increase
Binning / subsampling support	2x2 binning (simultaneous ROI-mode not supported)	No	2x2 binning
Reverse modes	for vertical or horizontal: normal or inverted readout	for vertical or horizontal: normal or inverted readout	for vertical or horizontal: normal or inverted readout
Trigger input	Yes in fast trigger mode	Yes in fast trigger mode	Yes in trigger mode
Flash output	Yes in fast trigger mode	Yes in fast trigger mode	Yes
Power consumption	250mA(@3.3V) typical, 300mA(@3.3V) max. when active	250mA(@3.3V) typical, 300mA(@3.3V) max. when active	80mA(@3.3V) typical, 100mA(@3.3V) max. when active
Standby current	20mA Hardware, 30mA Software	20mA Hardware, 30mA Software	20mA Hardware, 30mA Software
Operating temperature	-30 to +75 deg C, non-condensing	-30 to +75 deg C, non-condensing	-30 ... +85 deg C, non-condensing
Storage temperature	-40 to +85 deg C	-40 to +85 deg C	-40 ... +85 deg C
Performance guarantee temperature	-10 to +60 deg C	-10 to +60 deg C	0 ... +50 deg C
Supply voltage	3.3V +/- 5% at input of module (not including voltage drop on cable)	3.3V +/- 5% at input of module (not including voltage drop on cable)	3.3V +/- 5% at input of module (not including voltage drop on cable)

Technical Data: VC MIPI IMX290, VC MIPI IMX327 C, VC MIPI IMX412 C

Component / Feature	Module Name VC MIPI IMX290	Module Name VC MIPI IMX327 C	Module Name VC MIPI IMX412 C
CMOS Sensor	1/2.8" Sony IMX290, monochrome, 2.0 Mpixel	1/2.8" Sony IMX327 (better ver. of IMX290), color, 2.0 Mpixel	1/2.3" Sony IMX412, color, 12.3 Mpixel
Active pixels	1920(H) x 1080(V) (full HD)	1920(H) x 1080(V) (full HD)	4056(H) x 3040(V)
Pixel size	2.90(H) x 2.90(V) μm	2.90(H) x 2.90(V) μm	1.55(H) x 1.55(V) μm
Active sensor size	5.617(H) x 3.181(V) mm	5.617(H) x 3.181(V) mm	6.287(H) x 4.712(V) mm
Shutter type	Rolling Shutter	Rolling Shutter	Rolling Shutter
ADC Resolution	10 Bit / 12 Bit	10 Bit / 12 Bit	10 Bit / 12 Bit
CSI-2 output	2 lanes / 4 lanes (not 15pin connector) / RAW 10 or RAW 12	2 lanes / 4 lanes (not 15pin connector) / RAW 10 or RAW 12	2 lanes / 4 lanes (not 15pin connector) / RAW 10 or RAW 12
CSI-2 maximum speed	891 Mbps/lane max.	891 Mbps/lane max.	2.1 Gbps/lane max.
CSI-2 default speed	891 Mbps/lane	891 Mbps/lane	1.35 Gbps/lane
Max fps (full resolution)	120 fps at 10 Bit / 60 fps at 12 Bit (4 lanes)	60 fps at 10 Bit / 50 fps at 12 Bit (4 lanes)	40 fps at 10 Bit / 20 fps at 12 Bit (4 lanes)
Output modes	streaming mode	streaming mode	streaming mode
Shutter resolution	1 horizontal unit	1 horizontal unit	1 horizontal unit
Gain	0–30dB analog gain + 0–42dB digital gain	0–30dB analog gain + 0–42dB digital gain	0–27dB analog gain + 0–24dB digital gain
S/N ratio	n/a	n/a	n/a
dynamic range	n/a	n/a	n/a

Component / Feature	Module Name VC MIPI IMX290	Module Name VC MIPI IMX327 C	Module Name VC MIPI IMX412 C
HDR	Yes: digital overlap HDR + multiple exposure HDR	Yes: digital overlap HDR + multiple exposure HDR	Yes: DOL HDR (digital overlap HDR)
CRA	6.14 degrees	6.14 degrees	12 degrees
ROI / cropping support	Yes, but no speed increase	Yes, but no speed increase	Yes, but no speed increase
Binning / subsampling support	No	No	Subsampling + 2x2 binning
Reverse modes	for vertical or horizontal: normal or inverted readout	for vertical or horizontal: normal or inverted readout	for vertical or horizontal: normal or inverted readout
Trigger input	No	No	No
Flash output	No	No	No
Power consumption	150mA(@3.3V) typical, 200mA(@3.3V) max. when active	150mA(@3.3V) typical, 200mA(@3.3V) max. when active	150mA(@3.3V) typical, 200mA(@3.3V) max. when active
Standby current	20mA Hardware, 50mA Software	20mA Hardware, 50mA Software	20mA Hardware, 40mA Software
Operating temperature	-30 to +75 deg C, non-condensing	-30 to +85 deg C, non-condensing	-30 to +75 deg C, non-condensing
Storage temperature	-30 to +80 deg C	-40 to +85 deg C	-30 to +80 deg C
Performance guarantee temperature	-10 to +60 deg C	-10 to +60 deg C	-10 to +60 deg C
Supply voltage	3.3V +/- 5% at input of module (not including voltage drop on cable)	3.3V +/- 5% at input of module (not including voltage drop on cable)	3.3V +/- 5% at input of module (not including voltage drop on cable)

Technical Data: VC MIPI IMX183/VC MIPI IMX183 C, VC MIPI IMX226/VC MIPI IMX226 C, VC MIPI IMX415 C

Component / Feature	Module Name VC MIPI IMX183/VC MIPI IMX183 C	Module Name VC MIPI IMX226/VC MIPI IMX226 C	Module Name VC MIPI IMX415 C
CMOS Sensor	1" Sony IMX183, Mono/color, 20.2 Mpixel	1/1.7" Sony IMX226, Mono/color, 12.4 Mpixel	1/2.8" Sony IMX415C, color, 8.3 Mpixel
Active pixels	5440(H) x 3694(V)	3840(H) x 3046(V)	3840(H) x 2160(V)
Pixel size	2.40(H) x 2.40(V) μ m	1.85(H) x 1.85(V) μ m	1.45(H) x 1.45(V) μ m
Active sensor size	13.305(H) x 8.865(V) mm	7.533(H) x 5.635(V) mm	5.602(H) x 3.155(V) mm
Shutter type	Rolling Shutter with Global Reset	Rolling Shutter with Global Reset	Rolling Shutter
ADC Resolution	10 Bit / 12 Bit	10 Bit / 12 Bit	10 Bit / 12 Bit
CSI-2 output	2 lanes / 4 lanes (not 15pin connector) / RAW 8, 10 or 12	2 lanes / 4 lanes (not 15pin connector) / RAW 8, 10 or 12	2 lanes / 4 lanes (not 15pin connector) / RAW 10 or RAW 12
CSI-2 maximum speed	1.5 Gbps/lane max.	1.5 Gbps/lane max.	1.5 Gbps/lane max.
CSI-2 default speed	1.5 Gbps/lane	1.5 Gbps/lane	1.5 Gbps/lane
Max fps (full resolution)	26.9 fps at 8 and 10 Bit / 22.5 fps at 12 Bit (4 lanes)	43.6 fps at 8 and 10 Bit / 36.3 fps at 12 Bit (4 lanes)	60 fps at 10 Bit (4 lanes)
Output modes	streaming mode, fast trigger mode	streaming mode, fast trigger mode	streaming mode
Shutter resolution	1 horizontal unit	1 horizontal unit	1 horizontal unit
Gain	0–27dB analog gain + 0–18dB digital gain	0–27dB analog gain + 0–18dB digital gain	0–30dB analog gain + 0–42dB digital gain
S/N ratio	n/a	n/a	n/a
dynamic range	n/a	n/a	n/a
HDR	No	No	Yes: DOL HDR (digital overlap HDR) + multiple exposure HDR
CRA	3 degrees	9 degrees	6.12 degrees
ROI / cropping support	Yes, but no speed increase	Yes, but no speed increase	Yes, but no speed increase
Binning / subsampling support	Binning + subsampling	No	Binning
Reverse modes	for vertical or horizontal: normal or inverted readout	for vertical or horizontal: normal or inverted readout	for vertical or horizontal: normal or inverted readout
Trigger input	Yes	Yes	No
Flash output	Yes	Yes	No
Power consumption	450mA(@3.3V) max.	400mA(@3.3V) max.	150mA(@3.3V) typical, 200mA(@3.3V) max. when active
Standby current	70mA Software	70mA Software	20mA Hardware, 40mA Software
Operating temperature	-30 to +75 deg C, non-condensing	-30 to +85 deg C, non-condensing	-30 to +75 deg C, non-condensing
Storage temperature	-30 to +80 deg C	-40 to +85 deg C	-30 to +80 deg C
Performance guarantee temperature	-10 to +60 deg C	-10 to +60 deg C	-10 to +60 deg C
Supply voltage	3.3V +/- 5% at input of module (not including voltage drop on cable)	3.3V +/- 5% at input of module (not including voltage drop on cable)	3.3V +/- 5% at input of module (not including voltage drop on cable)

Technical Data: VC MIPI IMX252/VC MIPI IMX252 C, VC MIPI IMX250/VC MIPI IMX250 C, VC MIPI IMX273/VC MIPI IMX273 C

Component / Feature	Module Name VC MIPI IMX252/VC MIPI IMX252 C	Module Name VC MIPI IMX250/VC MIPI IMX250 C	Module Name VC MIPI IMX273/VC MIPI IMX273 C
CMOS Sensor	1/1.8" Sony IMX252, Mono/color, 3.15 Mpixel	2/3" Sony IMX250, Mono/color, 5.01 Mpixel	1/2.9" Sony IMX273, Mono/color, 1.56 Mpixel
Active pixels	2048(H) x 1536(V)	2448(H) x 2048(V)	1440(H) x 1080(V)
Pixel size	3.45(H) x 3.45(V) μ m	3.45(H) x 3.45(V) μ m	3.45(H) x 3.45(V) μ m
Active sensor size	7.066(H) x 5.299(V) mm	8.446(H) x 7.066(V) mm	4.970(H) x 3.726(V) mm
Shutter type	Global Shutter	Global Shutter	Global Shutter
ADC Resolution	8 Bit / 10 Bit / 12 Bit	8 Bit / 10 Bit / 12 Bit	8 Bit / 10 Bit / 12 Bit
CSI-2 output	2 lanes / 4 lanes (not 15pin connector) / RAW 8, 10 or 12	2 lanes / 4 lanes (not 15pin connector) / RAW 8, 10 or 12	2 lanes / 4 lanes (not 15pin connector) / RAW 10 or RAW 12
CSI-2 maximum speed	1.5 Gbps/lane max.	1.5 Gbps/lane max.	1.5 Gbps/lane max.
CSI-2 default speed	1.5 Gbps/lane	1.5 Gbps/lane	1.5 Gbps/lane
Max fps (full res., 4 lanes)	151.4 fps at 8 Bit / 123.5 fps at 10 Bit / TBD fps at 12 Bit	101.3 fps at 8 Bit / 82.5 fps at 10 Bit / 69.5 fps at 12 Bit	276.0 fps at 8 Bit / 226.5 fps at 10 Bit / 165.9 fps at 12 Bit
Output modes	streaming mode, fast trigger mode	streaming mode, fast trigger mode	streaming mode, fast trigger mode
Shutter resolution	1 horizontal unit	1 horizontal unit	1 horizontal unit
Gain	0–24dB analog gain + 0–24dB digital gain	0–24dB analog gain + 0–24dB digital gain	0–24dB analog gain + 0–24dB digital gain
S/N ratio	n/a	n/a	n/a
dynamic range	n/a	n/a	n/a
HDR	No	No	No
CRA	3 degrees	3 degrees	1.8 degrees
ROI / cropping support	Yes, but no speed increase	Yes, but no speed increase	Yes, but no speed increase
Binning / subsampling support	Binning + subsampling	Binning + subsampling	Binning + subsampling
Reverse modes	for vertical or horizontal: normal or inverted readout	for vertical or horizontal: normal or inverted readout	for vertical or horizontal: normal or inverted readout
Trigger input	Yes	Yes	Yes
Flash output	Yes	Yes	Yes
Power consumption	450mA(@3.3V) max.	450mA(@3.3V) max.	400mA(@3.3V) max.
Standby current	70mA Software	70mA Software	70mA Software
Operating temperature	-30 to +75 deg C, non-condensing	-30 to +85 deg C, non-condensing	-30 to +75 deg C, non-condensing
Storage temperature	-30 to +80 deg C	-40 to +85 deg C	-30 to +80 deg C
Performance guarantee temperature	-10 to +60 deg C	-10 to +60 deg C	-10 to +60 deg C

Component / Feature	Module Name	Module Name	Module Name
	VC MIPI IMX252/VC MIPI IMX252 C	VC MIPI IMX250/VC MIPI IMX250 C	VC MIPI IMX273/VC MIPI IMX273 C
Supply voltage	3.3V +/- 5% at input of module (not including voltage drop on cable)	3.3V +/- 5% at input of module (not including voltage drop on cable)	3.3V +/- 5% at input of module (not including voltage drop on cable)

Technical Data: VC MIPI OV7251

Component / Feature	Module Name	Module Name
	VC MIPI OV7251	VC MIPI IMX392/VC MIPI IMX392 C
CMOS Sensor	1/4" Omnivision OV7251, Monochrome, 0.3 Mpixel	1/2.3" Sony IMX392, Mono/color, 2.3 Mpixel
Active pixels	640(H) x 480(V)	1920(H) x 1200(V)
Pixel size	3(H) x 3(V) μm	3.45(H) x 3.45(V) μm
Active sensor size	1.92(H) x 1.44(V) mm	6.679(H) x 4.195(V) mm
Shutter type	Global shutter	Global Shutter
ADC Resolution	8 bit / 10 bit	8 Bit / 10 Bit / 12 Bit
CSI-2 output	1 lane / RAW 8 or RAW 10	2 lanes / 4 lanes (not 15pin connector) / RAW 8, 10 or 12
CSI-2 maximum speed	800 Mbps/lane max.	1.5 Gbps/lane max.
CSI-2 default speed	800 Mbps/lane	1.5 Gbps/lane
Max fps (full resolution)	104 fps	201.7 fps at 8 Bit / 167.0 fps at 10 Bit / 134.4 fps at 12 Bit
Output modes	streaming mode	streaming mode, fast trigger mode
Shutter resolution	in streaming mode: 1 horizontal unit	1 horizontal unit
Gain	analog and digital gain	0–24dB analog gain + 0–24dB digital gain
S/N ratio	38dB	n/a
dynamic range	68dB	n/a
HDR	No	No
CRA	29 degrees	2.24 degrees
ROI / cropping support	Yes, but no speed increase	Yes, but no speed increase
Binning / subsampling support	No	Binning + subsampling
Reverse modes	No	for vertical or horizontal: normal or inverted readout
Trigger input	No	Yes
Flash output	Yes	Yes
Power consumption	90mA(@3.3V) typical, 100mA(@3.3V) max. when active	450mA(@3.3V) max.
Standby current	35mA Hardware	70mA Software
Operating temperature	-30 ... +70 deg C, non-condensing	-30 to +75 deg C, non-condensing
Storage temperature	-30 ... +70 deg C	-30 to +80 deg C
Performance guarantee temperature	0 ... +50 deg C	-10 to +60 deg C
Supply voltage	3.3V +/- 5% at input of module (not including voltage drop on cable)	3.3V +/- 5% at input of module (not including voltage drop on cable)

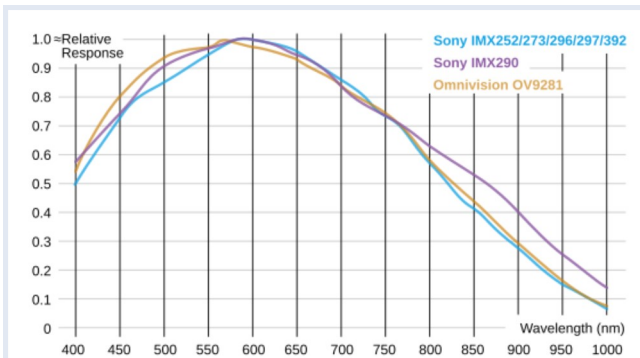

Spectral Curves of selected Monochrome Sensors (1)

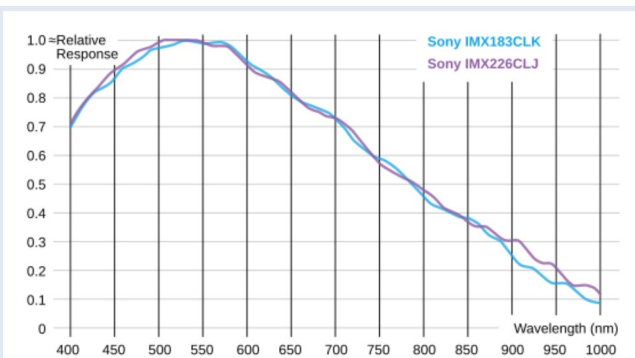

Spectral Curves of selected Monochrome Sensors (2)

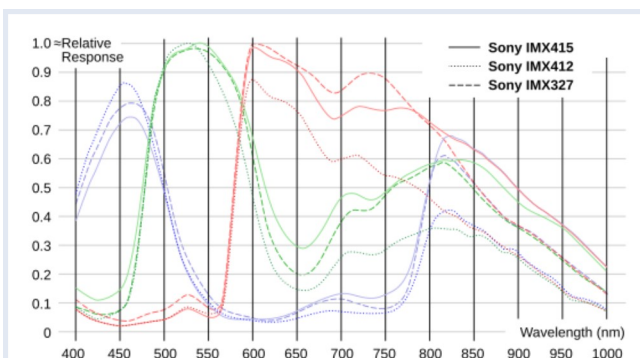

Spectral Curves of selected Color Sensors (1)

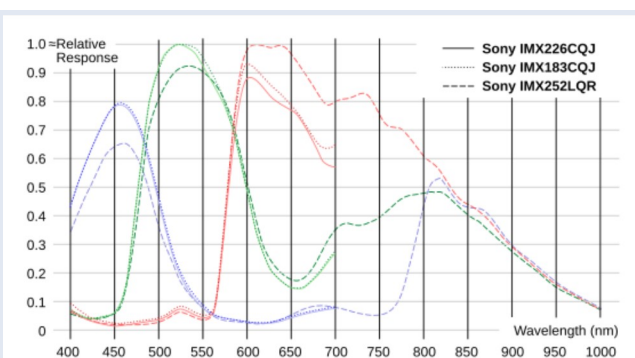

Spectral Curves of selected Color Sensors (2)

Note

Implementing a color calibration routine for color sensors is recommended!

1.3 Electrical and Mechanical Prerequisites

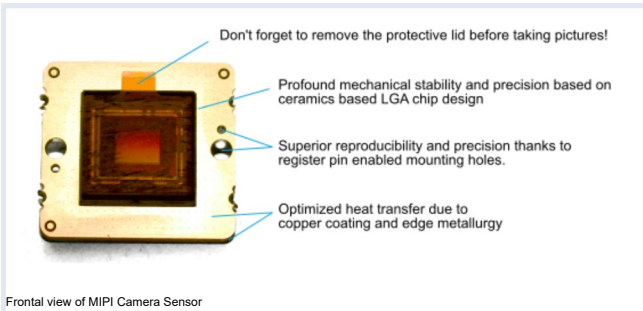

Before connecting, make sure that the pinout of the computer board fits the pinout of the MIPI module, especially the power supply (3V3) and GND pins. In 2014 a number of boards for the Compute Module IO (CMIO) have been sold with reverse pinout which may damage the MIPI Module and the Compute Module when connected. If in doubt contact the manufacturer or the dealer of the computer board. Vision Components can not take responsibility for incorrect pin-outs, changes and modifications of third party manufacturers.

Always use the original Vision Components FPC cable for connecting the MIPI Modules. FPC cables are available with 15 pin or 22 pin header on one side. The MIPI module side always has 22 pins. The original FPC cables connect the signal traces on one side and have a GND shield on the other side. Flat cables with only the signal wires without shielding are not suitable for this purpose.

Note



Please be aware that using the FPC cable with 15 pin on one side limits the number of MIPI data lanes to 2 (instead of 4 for the FPC cable with 22 pins on both sides). This may lead to lower frame rates than specified.

Make sure to connect the correct side of the cable with the MIPI Module. The correct side for the MIPI Module is marked "sensor side".

Due to the high transmission rate of about 1.5 Gbit/sec per lane the cable length is limited to 200mm. Using a repeater board the cable length can be doubled to 400mm.

1.4 Pin Cable Connector for Vision Components MIPI CSI camera modules

Data signals are compliant to MIPI CSI 2. Not all of the 4 lanes are supported for all sensor modules, e.g.:

- Raspberry Pi Compute Module IO V3.0: CAM0 connector supports 2 lanes only; CAM1 connector supports 4 lanes
- Raspberry Pi Zero V1.3 and Raspberry Pi 3B+ support 2 lanes only

1.4.1 Flexible Printed Circuit (FPC) Cable

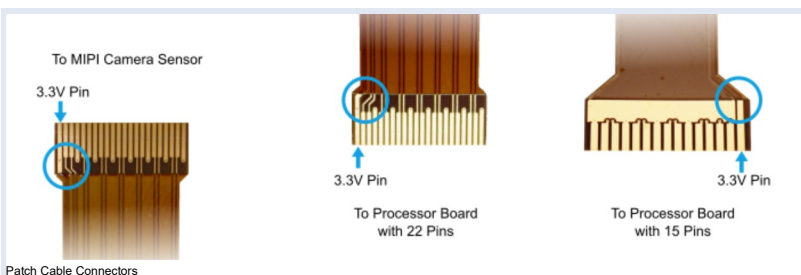
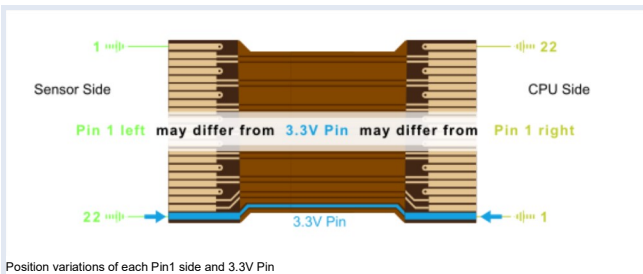

Warning



At the time of writing the schematics of the models 'Raspberry Pi CMIO V3.0' and the 'Raspberry Pi Zero V1.3' have the **pin numbering of the MIPI sensor connector in a wrong, inverse order**, so pin 1 would be pin 22, pin 2 would be pin 21, ...

- Always check cable numbering when connecting the sensor boards to hardware not from Vision Components!
- Vision Components is not liable to any damages by connecting to incompatible hardware!
- Always use original Vision Components FPC cable!
- FPC cable can only be used in one direction!

FPC Cable Signals

Signal Type	Sensor module	Processor board (22 Pin)		Processor board (15 Pin)
		regular	inverse	regular
GND	1	22	1	1
CSI_DAT0_N	2	21	2	2
CSI_DAT0_P	3	20	3	3
GND	4	19	4	4
CSI_DAT1_N	5	18	5	5
CSI_DAT1_P	6	17	6	6

Signal Type	Sensor module	Processor board (22 Pin)		Processor board (15 Pin)
		regular	inverse	regular
GND	7	16	7	7
CSI_CLK_N	8	15	8	8
CSI_CLK_P	9	14	9	9
GND	10	13	10	10
CSI_DAT2_N	11	12	11	—
CSI_DAT2_P	12	11	12	—
GND	13	10	13	—
CSI_DAT3_N	14	9	14	—
CSI_DAT3_P	15	8	15	—
GND	16	7	16	—
trigger_to_sensor [1] [2]	17	6	17	11
flash_from_sensor [1] [2]	18	5	18	12
GND	19	4	19	—
I2C_SCL [2]	20	3	20	13
I2C_SDA [2]	21	2	21	14
Vcc3V3	22	1	22	15

[1] (1, 2) not supported for all sensor modules.

[2] (1, 2, 3, 4) signals have 3.3V LVTTTL/LVCMOS level.

1.4.1.1 FPC Cable End to MIPI Camera Sensor

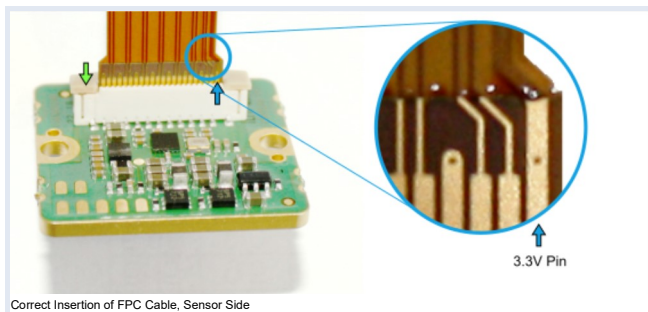
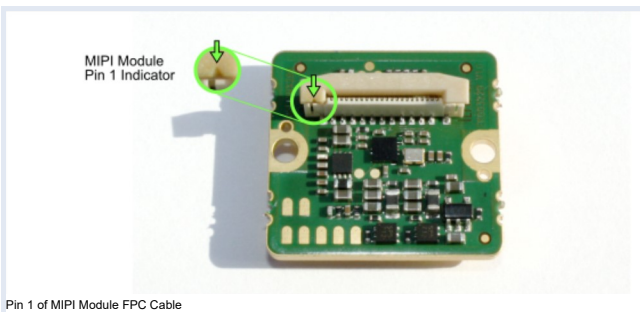

1.4.1.2 FPC Cable End to Processor Board

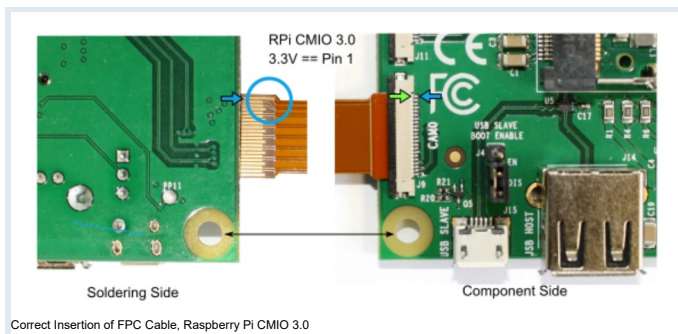

1.5 MIPI Sensor Module Circuit

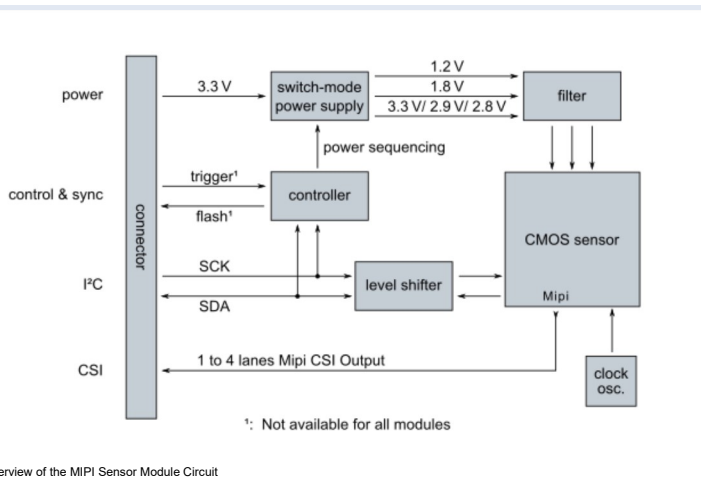

Overview of the MIPI Sensor Module Circuit

1.6 Trigger Timing

Some sensors have fast trigger input capability and flash output for synchronizing LED flashes. The following figure explains the timing of the signals.

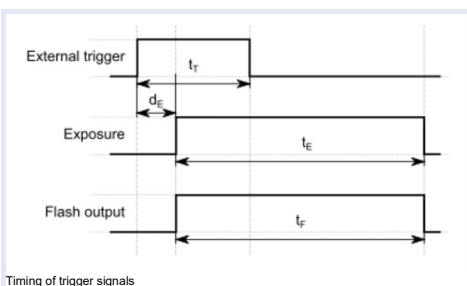

Timing of trigger signals

Trigger timing by sensor type

Time	VC MIPI OV9281	VC MIPI IMX296
trigger duration t_T	>9 μ s	>10 μ s
trigger delay d_E	0.832 ms	5 μ s due to debouncing
trigger delay jitter	42 ns max.	18.5 ns max.
exposure duration t_E	programmable	step size 18.5 ns
flash duration t_F	programmable	$t_F = t_E$

2 Ordering Information

2.1 MIPI camera module order numbers

VC MIPI camera modules

Order Number	Product ID	Service description
VK000434	VC MIPI IMX296	monochrome
VK003315	VC MIPI IMX296 C	color
VK003316	VC MIPI IMX297	monochrome
VK000469	VC MIPI OV7251	monochrome
VK000436	VC MIPI OV9281	monochrome
VK000438	VC MIPI IMX290	monochrome
VK000435	VC MIPI IMX327 C	color
VK000437	VC MIPI IMX412 C	color
VK000449	VC MIPI IMX415 C	color
VK000477	VC MIPI IMX183	monochrome
VK000482	VC MIPI IMX183 C	color
VK000478	VC MIPI IMX226	monochrome
VK000499	VC MIPI IMX226 C	color
VK004002	VC MIPI IMX252	monochrome
VK000493	VC MIPI IMX252 C	color
VK000481	VC MIPI IMX250	monochrome
VK000492	VC MIPI IMX250 C	color
VK000487	VC MIPI IMX273	monochrome
VK000495	VC MIPI IMX273 C	color
VK004003	VC MIPI IMX392	monochrome
VK000494	VC MIPI IMX392 C	color

2.2 Order numbers of MIPI camera module Accessories

Accessories for VC MIPI camera modules

Order Number	Product / Service description
EK003260	Flexible Printed Circuit (FPC) Cable, 200 mm: 22 to 22 Pin
EK003261	Flexible Printed Circuit (FPC) Cable, 200 mm: 22 to 15 Pin
VK000057	S-Mount Lens Holder (Plastic, NOT FOR IMX183, IMX252, IMX250, IMX392)
VK000454	CS-/C-Mount Lens Holder (NOT FOR IMX183, IMX252, IMX250, IMX392)
VK000483	C-Mount Lens Holder for IMX183, IMX252, IMX250, IMX392
VK000021	Lens, S-Mount Monochrome, f=8.0
VK000252	Lens, S-Mount Monochrome, f=3.6, F=1.8, 2-3 MPx
EK002697	Lens, S-Mount Monochrome, f=8.0, F=5.6
VK003117	Lens, S-Mount Monochrome, f=8.0, F=2.5, 1:1.8" macro
VK003137	Lens, S-Mount Monochrome, f=6.0, F=2.4, 1:2", 2-3 MPx
VK002066	Lens, S-Mount Monochrome, f=12.0, F=2.8, 1:2.5", 5 MPx
VK001256	Lens, S-Mount Color (IR filter), f=2.4, F=2.0, 1:3"
EK000625	Circular IR Filter Glass, d=16 mm
EK003348	VC MIPI 96 Adapter Board for '96' Boards



S-Mount Lens Holder (Plastic)

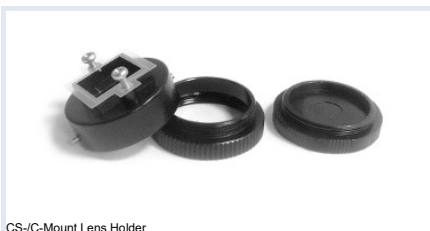

CS-/C-Mount Lens Holder

3 Appendix A: Dimensions MIPI camera module

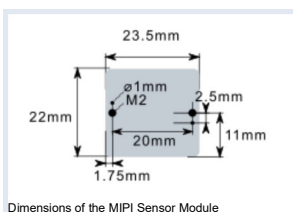

Dimensions of the MIPI Sensor Module

3.1 VC MIPI IMX296 (same board dimensions for OV9281, OV7251, IMX297, IMX290, IMX327, IMX412, IMX415)

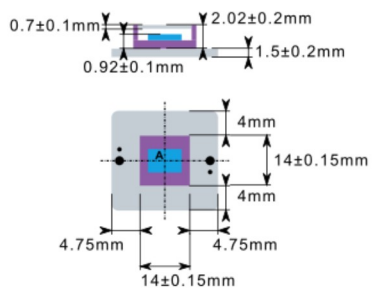
Sony IMX296, Sony IMX273

A: Center of the effective Image Area, $\pm 0.1\text{mm}$ wrt. package
 Rotation angle of the effective Image Area: $\pm 0.1\text{deg}$
 Tilt of the effective Image Area: $< 50\mu\text{m}$
 Refractive index of cover glass: 1.5

Dimensions of the VC MIPI IMX296

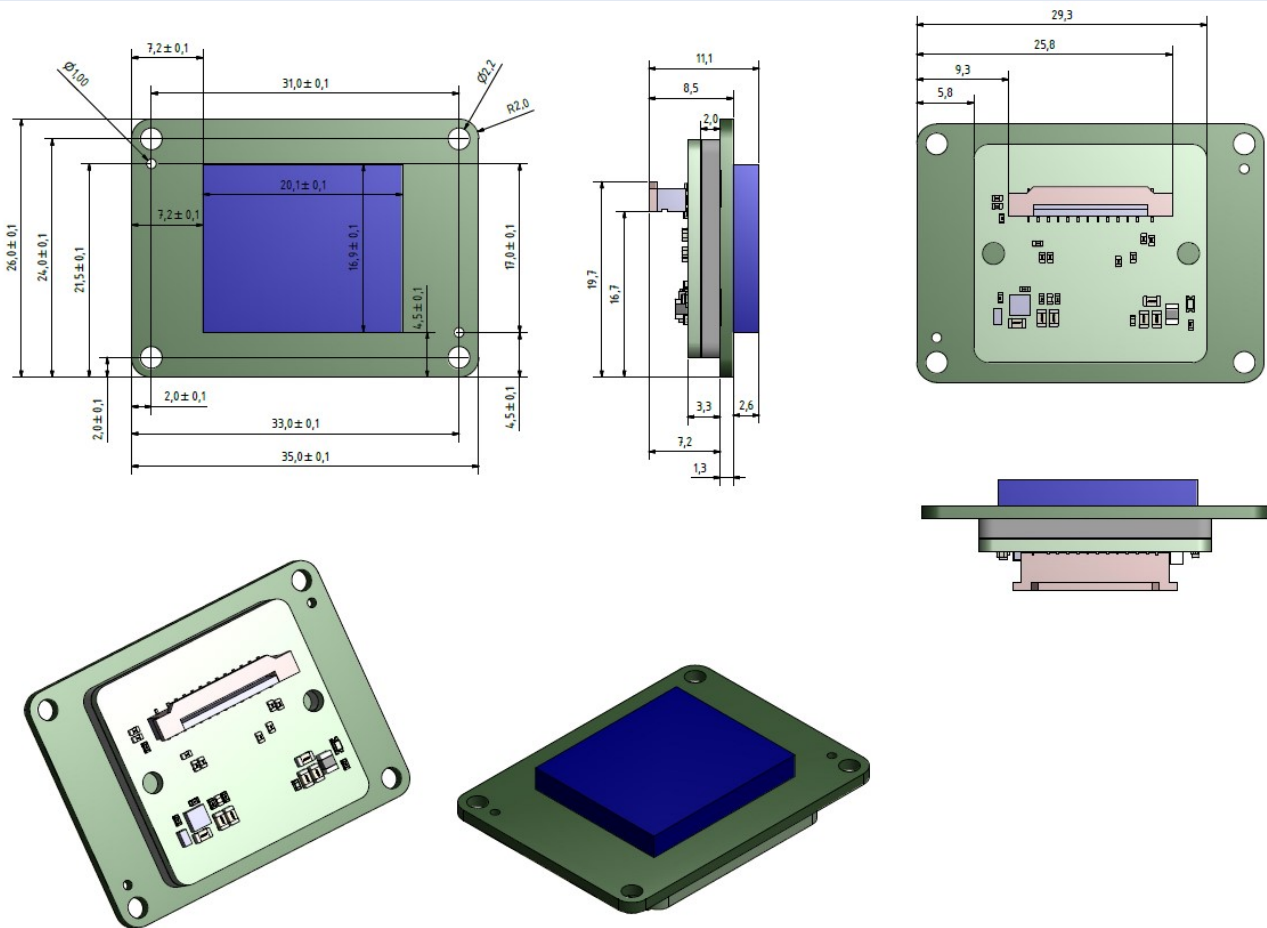
3.2 VC MIPI IMX183 (same board dimensions for IMX252, IMX250, IMX392)

Dimensions of the VC MIPI IMX183

3.3 VC MIPI IMX226 (same board dimensions for IMX273)

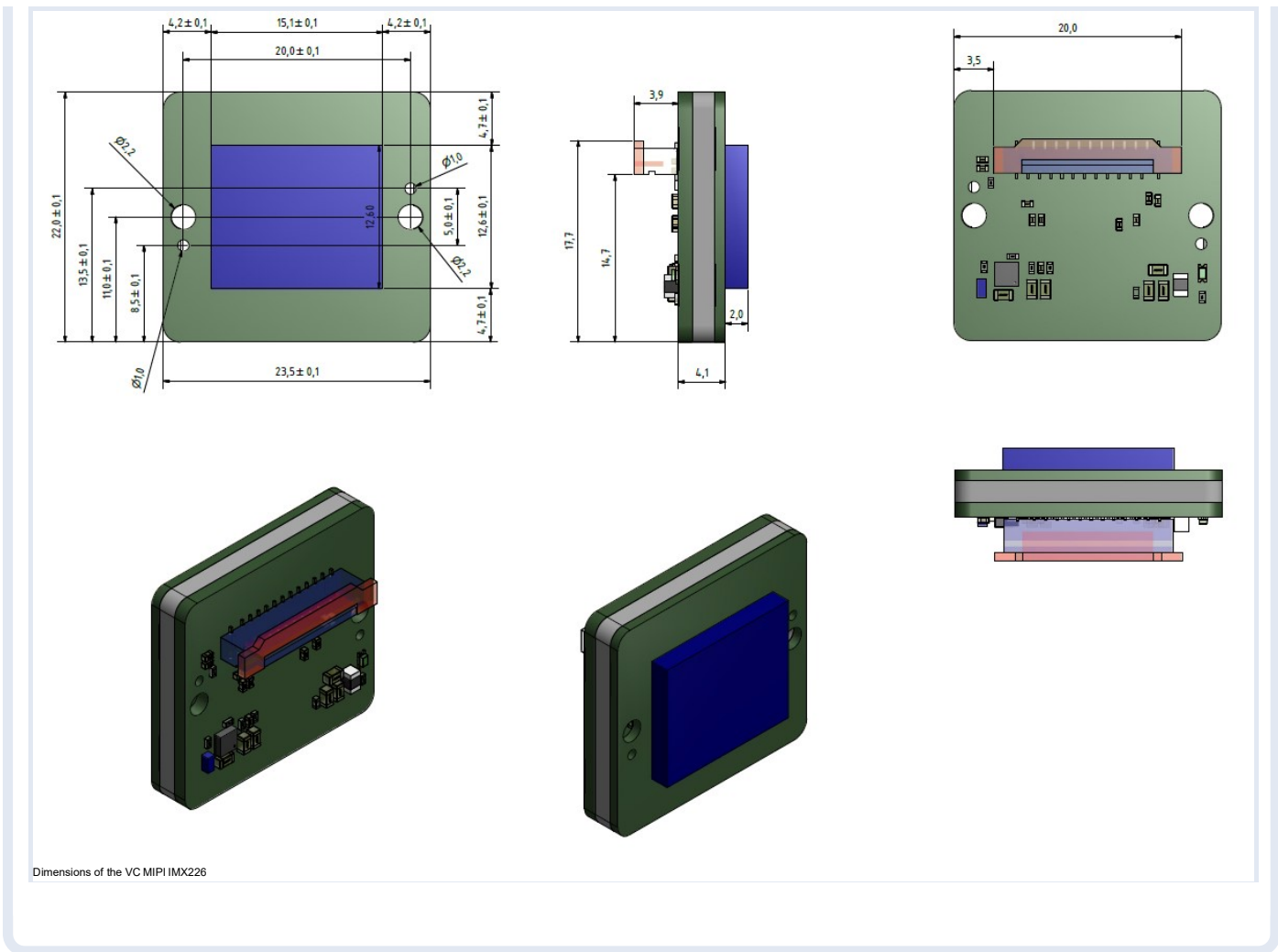

Vision Components GmbH
 Ottostr. 2
 76275 Ettlingen
 Germany

Phone: +49 (0) 7243 2167-0
www.vc-linux.com
www.vision-components.com