

VC nano 3D-Z Series Operating Manual

Hardware specifications of VC nano 3D-Z Smart Cameras

Revision: 1.1

Date: 2018-10-29

Contact: support@vision-comp.com

Copyright: 1996-2018 Vision Components GmbH Ettlingen, Germany

Author: VC Support, <mailto:support@vision-comp.com>





Foreword and Disclaimer

This documentation has been prepared with most possible care. However Vision Components GmbH does not take any liability for possible errors. In the interest of progress, Vision Components GmbH reserves the right to perform technical changes without further notice.

Please notify support@vision-components.com if you become aware of any errors in this manual or if a certain topic requires more detailed documentation.

This manual is intended for information of Vision Component's customers only. Any publication of this document or parts thereof requires written permission by Vision Components GmbH.

Image symbols used in this document

Symbol	Meaning
	The Light bulb highlights hints and ideas that may be helpful for a development.
	This warning sign alerts of possible pitfalls to avoid. Please pay careful attention to sections marked with this sign.
	This is a sign for an example.

Trademarks

Linux, Debian, the Tux logo, Vivado, Xilinx and Zynq, ARM, Cortex, Windows XP, Total Commander, Tera Term, Motorola, HALCON, Vision Components are registered Trademarks. All trademarks are the property of their respective owners.

Table of Contents

- 1 General Information
 - 1.1 Technical Specification VC nano 3D-Z
 - 1.1.1 Framerate calculation
 - 1.1.2 Measurement specifications
- 2 Hardware Interfaces
 - 2.1 Power Connector J₀
 - 2.1.1 J₀ Pin Assignment
 - 2.1.2 Electrical Specification: Camera Power Supply
 - 2.1.3 Electrical Specification: Digital PLC I/O, Encoder
 - 2.1.4 Encoder input specification VC nano 3D-Z Series
 - 2.2 Ethernet Connector J_E
 - 2.2.1 J_E Pin Assignment
 - 2.3 Electrical Specification: Laser
 - 2.4 Status LEDs
- 3 Software Interfaces
 - 3.1 GPIOs
 - 3.2 Encoder Configuration
- 4 Accessories
 - 4.1 Camera order numbers
- 5 Appendix A: Dimensions VC nano 3D-Z Series

1 General Information

Technical Data

Component / Feature	Specification
Laser	Class 2, <100mW average, wave length 450nm
CMOS Sensor	1/2.9" sony IMX273LLR, monochrome version
Active pixels	1408(H) x 1080(V)
Pixel size	3.45(H) x 3.45(V) μ m
Active sensor size	4.8(H) x 3.7(V) mm
High-speed shutter	1 μ sec + steps of 1 μ sec
Integration	Global shutter
Data acquisition	program-controlled or external high speed trigger, jitter-free acquisition full-frame up to 174 frames per second
A/D conversion	10 bit, 8 bits used after LUT application
Input LUT	1024 x 8 bits
Image Display	Via Ethernet onto PC
Processor	Dual-Core ARM® Cortex®-A9 with 866MHz and integrated FPGA
FPGA	Laser line processing during image acquisition in FPGA
RAM	512 MB DDR-SDRAM
Flash EPROM	16 GB flash memory (nonvolatile) industrial eMMC
Process interface	See following description.
Encoder Inputs	Yes, and encoder inputs can be used as additional 5-24V inputs.
Trigger Input	Encoder Signal A can be used as trigger input.
Ethernet interface	1 Gbit / 100 Mbit / 10 Mbit
CE certification	CE Certification from Vision Components
Storage Conditions	Temperature -20 to +60 deg C, Max. humidity: 90%, non condensing.
Operating Conditions	Temperature: 0 to +50 deg C, Max. humidity: 80%, non condensing.
Power Supply	24V DC, 300mA without I/O usage.
Power Consumption	7.2 W typical without I/O usage.

1.1 Technical Specification VC nano 3D-Z

1.1.1 Framerate calculation

the framerate can be calculated by following these subcalculations:

1. Calculate the time for a video line: $T_{Line} = HMAX * 13.468 \text{ ns}$.
2. Calculate the time for storing the captured image: $T_{Capt} = (DY + 33 + FPGA\text{Delay}) * T_{Line} + 3.3\mu\text{s}$.
3. Calculate the total time: $T_{Total} = Shutter\text{Time} + T_{Capt}$.

FPGA Delay: between 7 and 38 depending on the filter configuration.

HMAX vs. DX

DX	HMAX	T_{Line} (us)
1408	370	4.983
1344	350	4.713
1280	330	4.444
1216	320	4.310
1152	300	4.040
1088	290	3.906
1024	270	3.636
960	250	3.367
896	240	3.232
840	240	3.232
800	240	3.232

The following tables show some examples.

frame time (ms) at NrOfProcessingLines=7, shutter=1us

DY/DX	1408	1344	1280	1216	1152	1088	1024	960	896	840	800
1080	5.584	5.283	4.981	4.830	4.529	4.378	4.076	3.774	3.623	3.623	3.623
1024	5.305	5.019	4.732	4.589	4.302	4.159	3.872	3.586	3.442	3.442	3.442
960	4.986	4.717	4.448	4.313	4.044	3.909	3.640	3.370	3.236	3.236	3.236
800	4.189	3.963	3.737	3.623	3.397	3.284	3.058	2.832	2.718	2.718	2.718
512	2.754	2.605	2.457	2.382	2.234	2.159	2.011	1.862	1.788	1.788	1.788
256	1.478	1.399	1.319	1.279	1.199	1.159	1.080	1.000	0.960	0.960	0.960
128	0.840	0.795	0.750	0.727	0.682	0.659	0.614	0.569	0.546	0.546	0.546

frame time (ms) at NrOfProcessingLines=38, shutter=1us

DY/DX	1408	1344	1280	1216	1152	1088	1024	960	896	840	800
1080	5.739	5.429	5.119	4.964	4.654	4.499	4.189	3.879	3.724	3.724	3.724
1024	5.460	5.165	4.870	4.722	4.428	4.280	3.985	3.690	3.543	3.543	3.543
960	5.141	4.863	4.586	4.447	4.169	4.030	3.752	3.475	3.336	3.336	3.336
800	4.344	4.109	3.874	3.757	3.522	3.405	3.171	2.936	2.819	2.819	2.819

DY/DX	1408	1344	1280	1216	1152	1088	1024	960	896	840	800
512	2.908	2.751	2.594	2.516	2.359	2.280	2.123	1.966	1.888	1.888	1.888
256	1.633	1.545	1.457	1.413	1.325	1.280	1.192	1.104	1.060	1.060	1.060
128	0.995	0.941	0.888	0.861	0.807	0.781	0.727	0.673	0.647	0.647	0.647

maximum frame rate (fps) at NrOfProcessingLines=7, shutter=1us

DY/DX	1408	1344	1280	1216	1152	1088	1024	960	896	840	800
1080	179	189	201	207	221	228	245	265	276	276	276
1024	188	199	211	218	232	240	258	279	290	290	290
960	201	212	225	232	247	256	275	297	309	309	309
800	239	252	268	276	294	304	327	353	368	368	368
512	363	384	407	420	448	463	497	537	559	559	559
256	676	715	758	782	834	863	926	1000	1042	1042	1042
128	1190	1258	1333	1375	1466	1516	1628	1758	1830	1830	1830

maximum frame rate (fps) at NrOfProcessingLines=38, shutter=1us

DY/DX	1408	1344	1280	1216	1152	1088	1024	960	896	840	800
1080	174	184	195	201	215	222	239	258	269	269	269
1024	183	194	205	212	226	234	251	271	282	282	282
960	195	206	218	225	240	248	266	288	300	300	300
800	230	243	258	266	284	294	315	341	355	355	355
512	344	363	385	397	424	439	471	509	530	530	530
256	612	647	687	708	755	781	839	906	943	943	943
128	1005	1062	1126	1162	1239	1281	1376	1485	1547	1547	1547

Note



The measurements were done without any other CPU load. Parallel image processing tasks may lead to a lower framerate. These values are only reachable if image capturing is deactivated.

1.1.2 Measurement specifications

VC offers a wide range of models of VC nano 3D-Z sensors concerning field of view and resolution. The following table shows some examples. For additional models see the links below. Please contact us for custom designs.

VC nano 3D-Z model range

Model (focal distance [mm] / angle [deg])	(8/30) regular	(8/34) regular	(8/30) large	(8/34) large	(8/30) xlarge	(8/34) xlarge	(8/30) xxlarge	(8/34) xxlarge	(6/32) regular
Minimal distance Z [mm]	90	80	170	150	285	245	460	400	70
Maximal distance Z [mm]	245	195	470	375	785	625	1285	1020	285
Min. horizontal field of view X [mm]	65	65	130	120	215	200	350	325	80
Max. horizontal field of view X [mm]	150	125	295	240	495	400	810	660	230
Resolution X Min [μm]	60	50	110	100	170	160	280	260	70
Resolution X Max [μm]	120	100	240	190	390	320	640	520	190
Resolution Z Min [μm]	10	10	20	20	30	30	40	40	10
Resolution Z Max [μm]	40	30	80	60	130	90	220	150	70

A more comprehensive list of possible models:

[VC nano 3D Z 6/xx regular](#)

[VC nano 3D Z 8/xx regular](#)

[VC nano 3D Z 12/xx regular](#)

[VC nano 3D Z 6/xx large](#)

[VC nano 3D Z 8/xx large](#)

[VC nano 3D Z 12/xx large](#)

[VC nano 3D Z 6/xx xlarge](#)

[VC nano 3D Z 8/xx xlarge](#)

[VC nano 3D Z 12/xx xlarge](#)

[VC nano 3D Z 8/xx xxlarge](#)

[VC nano 3D Z 12/xx xxlarge](#)

2 Hardware Interfaces

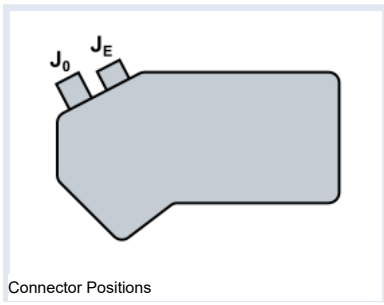

The VC nano 3D-Z camera incorporates the following connector interfaces:

Nomenclature for Connectors

Connector	Description
J ₀	Power Connector
J _E	Ethernet Connector

A detailed description of the connectors follows below.

2.1 Power Connector J₀

2.1.1 J₀ Pin Assignment

Pin Assignment of J₀ Connector (M12 A-Coding Binder 09-3491-600-12 - male)

Camera Socket Rear View	Pin	Signal	Level	Cable Standard Color
	1	Main Power Supply	+24V	brown
	2	Common Ground	GND	blue
	3	INP 0 or Laser Enable	+5-24V	white
	4	OUT 0	+24V	green
	5	INP 1 or ENC Z or Trigger Enable	+5-24V	pink
	6	OUT 1	+24V	yellow
	7	OUT 2	+24V	black
	8	INP 2 or ENCA or TrigIn	+5-24V	grey
	9	OUT 3 or TrigOut	+24V	red
	10	INP 3 or ENC /B	+5-24V	purple
	11	INP 4 or ENC B	+5-24V	grey/pink
	12	INP 5 or ENC /A	+5-24V	red/blue

All outputs are high-side switches, 24V, 400mA max.

All inputs and encoder inputs are 5-24V, 3mA, 200kHz max.

Signal Description

Signal	Description
INP 0 – INP 5	PLC inputs.
OUT 0 – OUT 3	PLC outputs.
Laser Enable	Hardware safety signal for the activation of the laser, must be set to high to enable the laser. It completely shuts down the power supply of the laser. Feature depending on hardware option. Does not influence triggering.
TrigIn	External trigger for image capture.
Trigger Enable	External signal to activate capturing, must be set to high for the complete capturing process. If signal is set to low, triggers will be blocked.
ENC A, ENC /A, ENC B, ENC /B, ENC Z	Encoder signals.

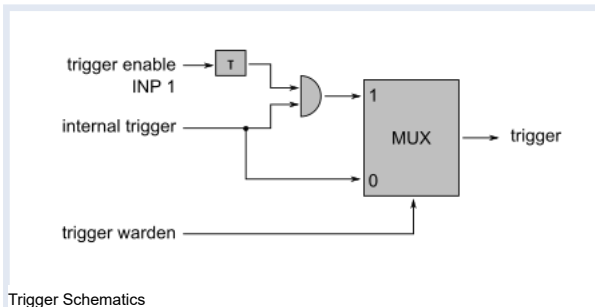

If the Laser Warden is used and no Laser Enable is given, the capture will be done nevertheless but without active laser.

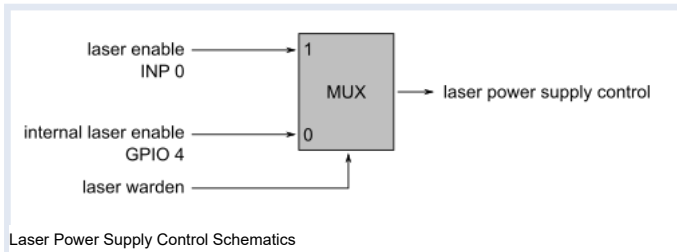

2.1.2 Electrical Specification: Camera Power Supply

Voltage/Current Overview

What	How much
Nominal Voltage	+24V
Absolute Maximum Voltage Limit	+32V
Minimum recommended Operating voltage	21.6V
Maximum recommended Operating voltage	26.4V
Operating Current (Typical)	260mA
Operating Current (Maximum)	300mA
Nominal Power Consumption (Typical)	6.5W
Nominal Power Consumption (Maximum)	7.2W

2.1.3 Electrical Specification: Digital PLC I/O, Encoder

Electrical Specifications

Separation of PLC/trigger output voltage	PLC outputs supply not separated from power supply
PLC Input Voltage	+5–24V
Input Current (max)	3mA, Threshold: Positive: +1.3mA typ., Negative: 0.7mA typ.
PLC Output Voltage	24V
PLC Output Current (max)	4 x 400 mA Max total of all outputs: 1A
Max Current for 1 Power / PLC connector pin	400 mA
Loads	Resistive, inductive and capacitive possible
Output Protection	Yes: short circuit, overcurrent, temperature
Power failure detection	Yes, power failure detected if total PLC current > 1A

Warning



If power failure is detected, all PLC outputs may switch off regardless of their output state for hardware protection.

2.1.3.1 Connection of PLC, Encoder inputs VC nano 3D-Z Series

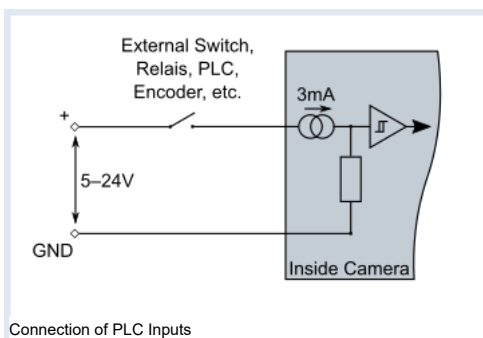

2.1.3.2 Connection of PLC outputs VC nano 3D-Z Series

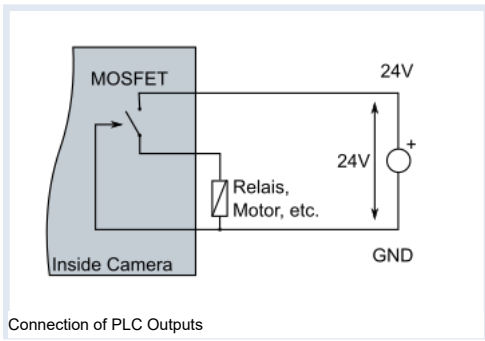

2.1.4 Encoder input specification VC nano 3D-Z Series

It is possible to connect the following encoder signals: ENC A, ENC /A, ENC B, ENC /B, ENC Z. There is no connection provided for signal ENC Z.

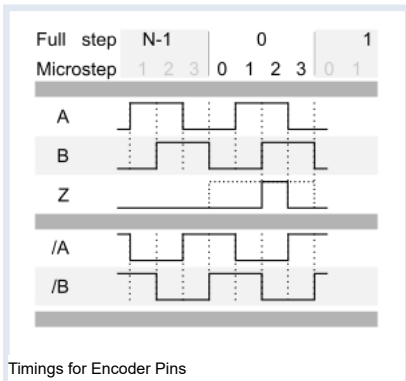

Supported Encoder Connection Configurations

ENC A	ENC /A	ENC B	ENC /B	ENC Z	Remarks
X	—	—	—	—	Not recommended
X	X	—	—	—	
X	—	X	—	—	Only recommended for cables < 5m
X	—	X	—	X	Only recommended for cables < 5m
X	X	X	X	—	Most noise tolerant
X	X	X	X	X	Most noise tolerant

Due to noise and signal bouncing the configuration using only ENC A signal is not recommended.

Pins not used for the encoder can be used as GPIO inputs.

It is possible to swap the signals A and B per software.

The maximum encoder frequency is limited to 200 kHz.

2.1.4.1 Encoder Counter

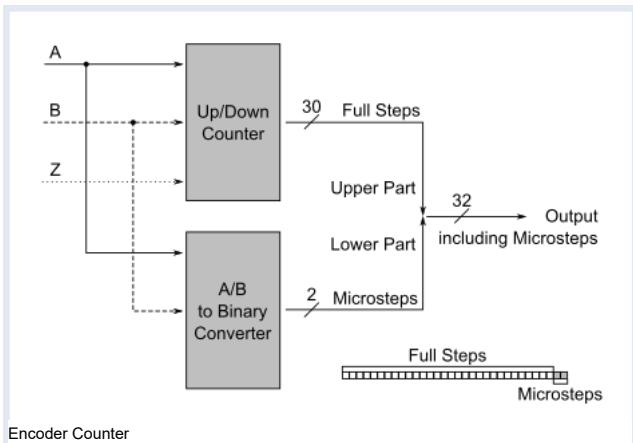

All internal encoder values represent positions with microstep resolution: A counter is used internally for counting the full-steps (Bits 31 to 2), whereas the microsteps (Bits 2 to 0) are directly derived from the encoder signals ENC A and ENC B.

The ENC Z signal is detected during microsteps 1 and 2. It resets the full-step counter without resetting the value of the microstep: i.e. the output value during reset can be 0, 1, 2 or 3 depending on the microstep position of the encoder.

If the ENC Z signal is used, the user must program the full-step resolution of the encoder for correct operation. This number is usually documented at the data sheet of the encoder device. The encoder counts even before the first ENC Z signal is detected. Until then the encoder counter value may be considered as invalid. It is a common

practice to calibrate the encoder, moving it to a zero position (reference) first. For your convenience the GPIO input signal 28 is provided indicating that a first ENC Z impulse has been detected. Loss of calibration is indicated if the GPIO input signal 27 is set. This may happen if the ENC Z signal is inconsistent with the full-step resolution. This may occur due to noise, broken cable or a wrong setting for the encoder full-step resolution.

The encoder position at the image trigger is stored in memory for possible later reference.

Note



In case of doubt, the correct programming of the encoder's full-step resolution is verifiable over the GPIO signal 27.

2.1.4.2 Encoder Trigger

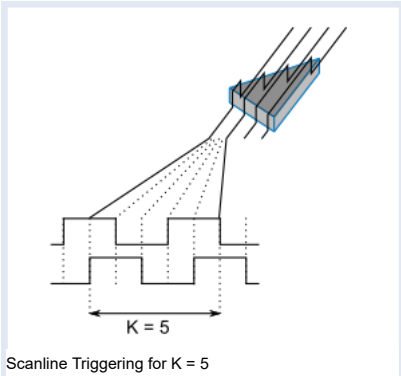

This internal hardware module allows for the generation of triggers every K microsteps (see figure). It allows to control the spacing of the scanlines with high resolution. At very low encoder speed the encoder position may occasionally move slightly backwards. In this case there will be no trigger until the encoder reaches the next valid trigger position in forward direction.

Although the encoder trigger is internal, for the image acquisition it acts as like an 'external trigger'. Triggers may be lost during the image acquisition time.

At startup time the system is in an uncalibrated state. This state can also be re-entered when the program 'vcio' is called without the option '-R'. When the first ENC Z signal occurs, the system is calibrated, i.e. the encoder position is set to zero plus the current microstep and the next trigger position is set as follows:

$$\text{trigger position} = \text{microstep} + \text{trigger increment} + \text{trigger offset}.$$

The re-entering done at 'vcio' is a pseudo-calibration like using the Z signal at this encoder position which is all that is necessary for systems without an ENC Z signal.

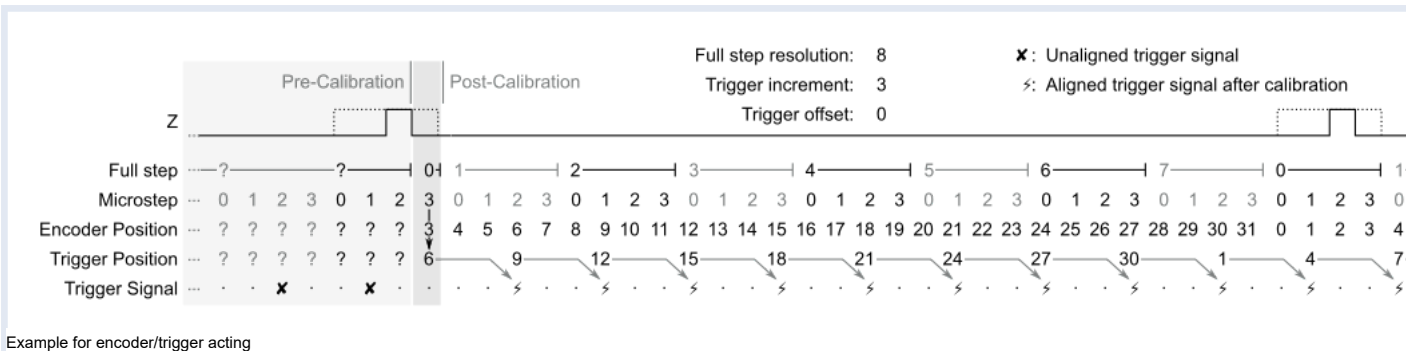

Example for encoder/trigger acting

Example

Given the encoder full-step resolution is 8 and the trigger increment 3. and the last trigger position of the first revolution is 30. The encoder counter then counts to encoder position 31 and wraps around to 0. The following trigger signals then occur at positions: 1, 4, 7, ...

Note



If increment plus offset is greater than or equals the full-step resolution times 4 trigger signals may never occur.

The encoder does not require an ENC Z signal. Such a system is called an uncalibrated system. It produces the trigger signals relative to a virtual zero which was set at the start of the system and can be set manually by calling 'vcio'. For systems using the ENC Z signal the situation is similar up to the point where the ENC Z signal occurs. I.e. there may be a number of uncalibrated trigger impulses before the occurrence of the ENC Z signal. After the occurrence of the ENC Z signal the system is calibrated, i.e. the trigger impulses are relative to the absolute zero set by the ENC Z signal at calibration time. The GPIO input signal 28 is provided indicating that a first ENC Z impulse has been detected.

Note



Always check the direction of the encoder movement if no or not enough trigger impulses occur. You can change the interpretation of the direction via the 'vcio' program.

Warning



During image acquisition, additional triggers may be lost.

2.2 Ethernet Connector J_E

2.2.1 J_E Pin Assignment

Pin Assignment of J_E Connector (M12 X-Coding Binder 09-3782-91-08 - female)

Camera Socket Rear View	Pin	Signal
	1	ETH_A_p
	2	ETH_A_n
	3	ETH_B_p
	4	ETH_B_n
	5	ETH_D_p
	6	ETH_D_n
	7	ETH_C_n
	8	ETH_C_p

2.3 Electrical Specification: Laser

Laser Information

Laser class	2
Power	<100mW
Wave length	450nm
Maximum pulse duration	100us
Maximum duty cycle	1:7

If the acquisition time exceeds the maximum pulse duration of the laser, the laser will be switched off.
 The duty cycle is limited to 1:7, i.e. the off-state is six times longer than the on-state for the laser output.

Example

100 us pulse duration, 600 us cool down duration.

?!

2.4 Status LEDs

The VC nano 3D-Z Smart Cameras feature 4 LEDs providing status information as listed at the following table.

Status LED	Meaning if light is turned on
POW: Power ON	The camera system is powered.
ON: Laser ON	The laser emits light.
OVL: Laser Overload	The laser does not emit light due to excess of the maximum allowed acquisition time.
EN: Laser Permission	The laser does not emit light due to missing permission.
STA: Trigger	Toggles on/off for each internal encoder trigger.

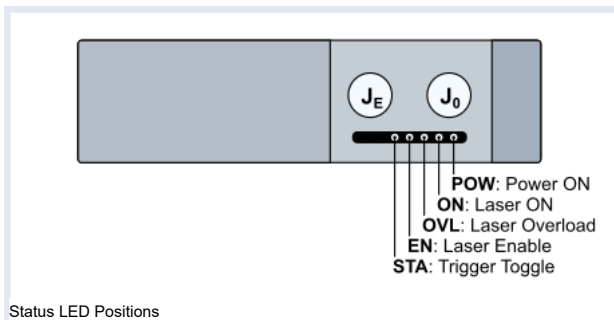

3 Software Interfaces

3.1 GPIOs

Connector Assignment of GPIOs

GPIO Nr.	Connector	Pin Designator	Usability	Remark
0	J ₀	OUT 0	Output	—
1	J ₀	OUT 1	Output	—
2	J ₀	OUT 2	Output	—
3	J ₀	OUT 3	Output	In case OUT 3 is configured as TrigOut, this GPIO inverts the polarity of the signal if set.
4	INTERNAL	Laser enable	Output	Activates laser power supply if set to 1, active only if external Laser Warden laser enable is not active.
5	—	—	—	—
6	—	—	—	—
7	—	—	—	—
8	—	—	—	—
9	—	—	—	—
10	J ₀	INP 0	Input	—
11	J ₀	INP 1	Input	—
12	J ₀	INP 2	Input	—
13	J ₀	INP 3	Input	—
14	J ₀	INP 4	Input	—
15	J ₀	INP 5	Input	—
16	—	—	—	—
17	—	—	—	—
18	—	—	—	—
19	—	—	—	—
20	—	—	—	—
21	—	—	—	—
22	—	—	—	—
23	—	—	—	—
24	—	—	—	—
25	—	—	—	—
26	—	—	—	—
27	INTERNAL	Counter mismatch detector	Input	Set to 1 if ENC Z impulse detected while internal counter not 0, requires encoder counter reset to be cleared.
28	INTERNAL	Encoder calibration done	Input	Set to 1 after first ENC Z impulse detected. Used to indicate the validity of the encoder counter values.
29	INTERNAL	MALFUNCTION	Input	—
30	—	—	—	—
31(Out)	—	—	—	—
31(In)	—	—	—	—

They can be accessed over the linux standard way via `/sys/class/gpio`, see <https://www.kernel.org/doc/Documentation/gpio/sysfs.txt>. The GPIO numbers are relative to the start number of the gpiochip labelled with 'amba@0/axi-gpio0@41200000', here: `/sys/class/gpio/gpiochip224`.

As an alternative the program called 'vcgpio' can be used for convenience. Sample usage instructions are provided here, but always refer to the instructions of your version:

```
08:11:57[root@VC-Z] ~ #vcgpio
```

```
VCGPIO v.1.0.0.- VCLinux Camera GPIO Setter/Getter.
```

```
Usage: vcgpio [-w val] [-f] <GPIO Nr.>
```

```
- Write the value given, valid values are 0 and 1. If this switch is not provided, a read operation will be done.
```

```
w
```

```
- Forces Operation. If a GPIO should be written, but the GPIO is configured as input, this switch will change the GPIO to act as an output and write the value.
```

```
f Forced read operations reconfigure the GPIO to be an input.
```

There are also wrapper functions provided at the libvclinux. Refer to its documentation.

3.2 Encoder Configuration

The program named 'vcio' can be used to setup the encoder. It provides usage information if no parameter is given. Sample usage instructions are provided here, but always refer to the instructions of your version:

```
08:11:57[root@VC-Z] ~ #vcio
```

```
VCIO v.1.2.2.- VCLinux Camera I/O Configuration and Connection Setup.
```

```
Usage: /tmp/vcio [-r MaxPos ] [-i Inc ] [-t time] [-a] [-b] [(-z | -e)] [-s] [-d] [-I] [-R] [-x]
```

```
- Define the encoder full-step resolution here, see encoder data sheet, if not defined, use default value of 2047.
```

```
r
```

```
- After the counter increments this count of microsteps, a trigger signal is being invoked which can be utilized by defining TRGSRC_EXT as trigger source.
```

```
i The least significant two bits represent the subincrement step. Note that counter resets to zero do not affect the state of the subincrements, i.e. after a reset the counter value can be 0, 1, 2 or 3. If not defined, use default value of 1.
```

```
- microstep offset for first trigger after calibration, first trigger occurs at microstep position increment (-i) plus offset (-o) plus 3. If not defined, use default value of 0.
```

```
- Interprets the signal at the corresponding PLCIn as encoder signal NA. On activation, connection is then mandatory.
```

```
a
```

```
- Interprets the signal at the corresponding PLCIn as encoder signal NB. On activation, connection is then mandatory.
```

```
b
```

```
- Interprets the signal at the corresponding PLCIn as encoder signal Z. On activation, connection is then mandatory. The switches -z and -e may never be set z simultaneously.
```

- Turn on Trigger Warden: The trigger signal is suppressed until the corresponding PLCIn signal is high active. The switches -z and -e may never be set simultaneously.
- Changes rotation direction (swaps signal A and B).
- Turns off the encoder signal B. Beware that just using signal A as increment, jitter may be present.
- Turn on Laser Warden: Laser is only activatable if the corresponding PLCIn is active. There are camera versions which do not allow the deactivation of the laser warden, and they act as if this parameter is always applied.
- Put sensor trigger output signal also to gpio Nr. 3.
- Time used to debounce encoder input source, default value: 10000. Time Unit is in FPGA Cycles. The FPGA clock frequency can be acquired by reading out the value of `capt->sen->d.fpgaClkHz`, e.g. 153846161 Hz. The default debouncing time for that example is then given by $10000 \text{ cycles} / 153846161 \text{ Hz} = 0.000065 \text{ s} = 65 \text{ us}$. If not defined, use default value of 10000.
- Suppresses reset of encoder hardware (GPIO Nr. 27, 28 and counter value will then remain unchanged)

Settings done cannot be read out. Different camera models may have different vco parameters.

Default Settings for Wardens

Target	Default Value
Trigger Warden	Inactive
Laser Warden	Inactive for cameras where the Laser Warden can be turned off, active else.

4 Accessories

4.1 Camera order numbers

VC nano 3D-Z Cameras

Order Number	Product / Service description
VK002861	VC nano 3D-Z 830
VK003122	VC nano 3D-Z 830 - Laser Safety

For other models please contact us.

5 Appendix A: Dimensions VC nano 3D-Z Series

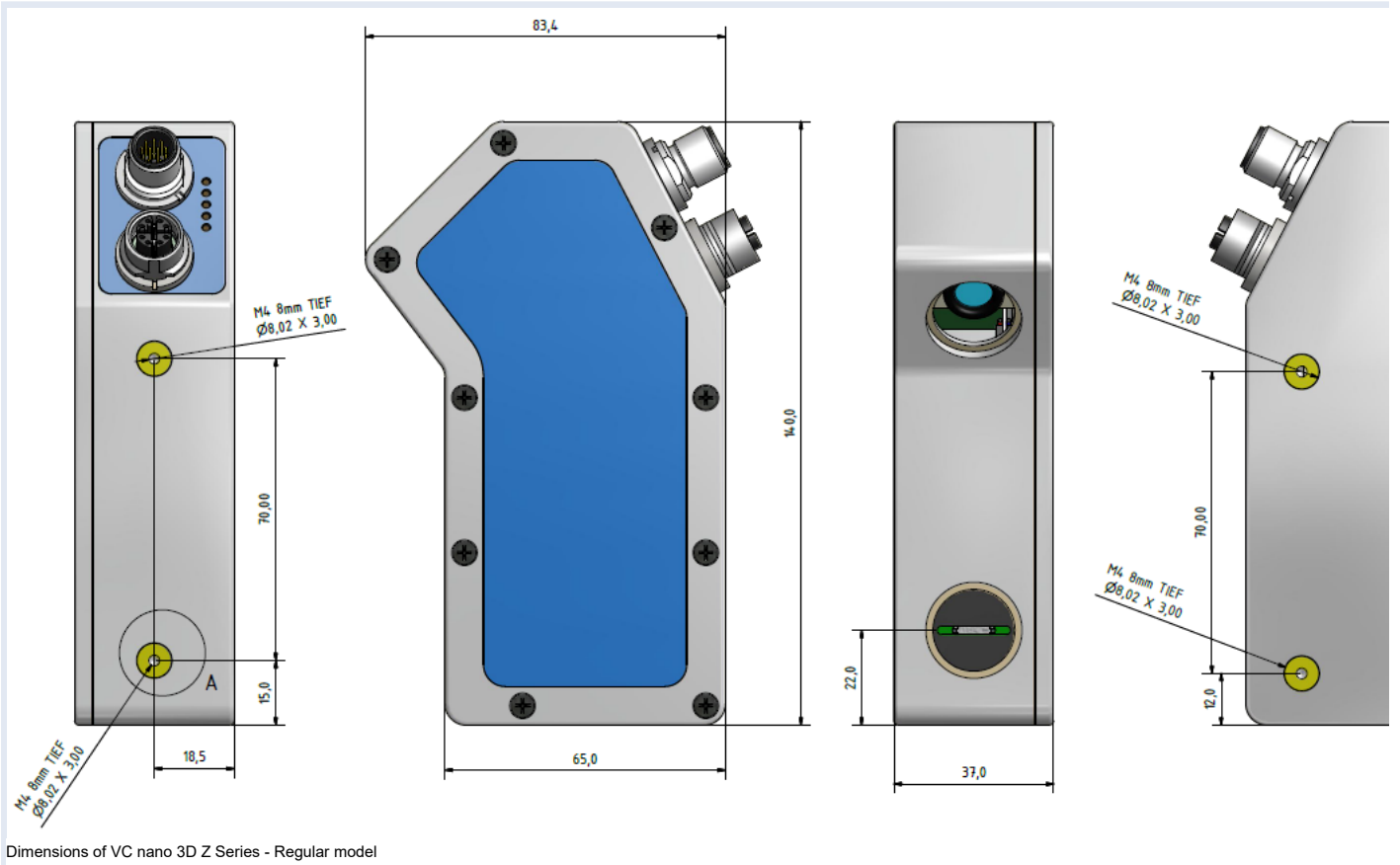

Vision Components GmbH
Ottostr. 2
76275 Ettlingen
Germany

Phone: +49 (0) 7243 2167-0
www.vc-linux.com
www.vision-components.com